

# **Building an ACO Post-Acute Network:**

**Effective Strategies for Contracting, Network Utilization, and  
Performance Monitoring**

**Tony Rodriguez, M.D.**





# UNC Health Alliance

**6,436** Providers with **2,316** Independent providers

**1,131** Primary care providers



**4,748** Specialty providers

**193** Specialties and subspecialties covered



SNF preferred network; home health preferred network

Community-based palliative care and hospice programs

## UNCHA Network Across North Carolina

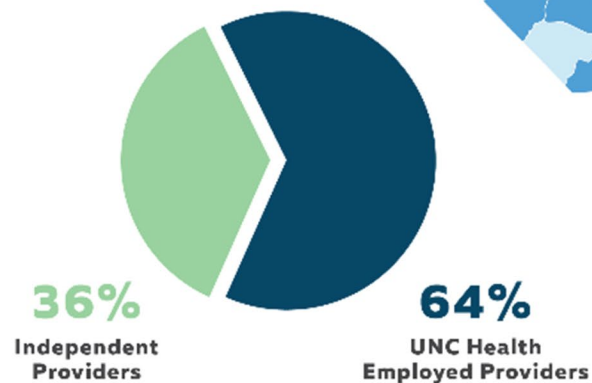
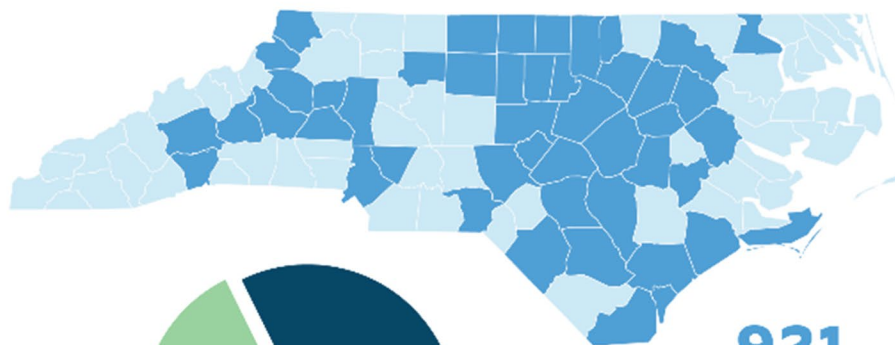

**921** Locations in **48** Counties

**12** Hospitals

# UNC Health Alliance

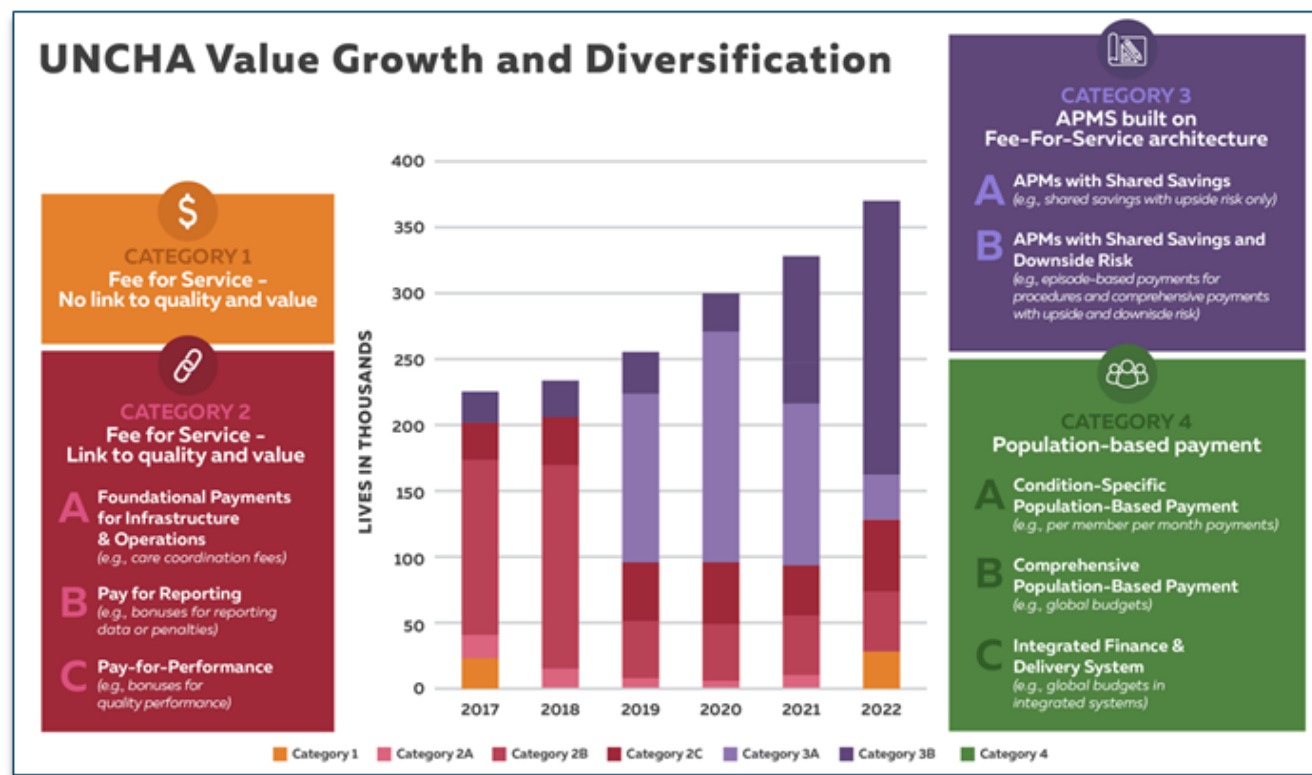
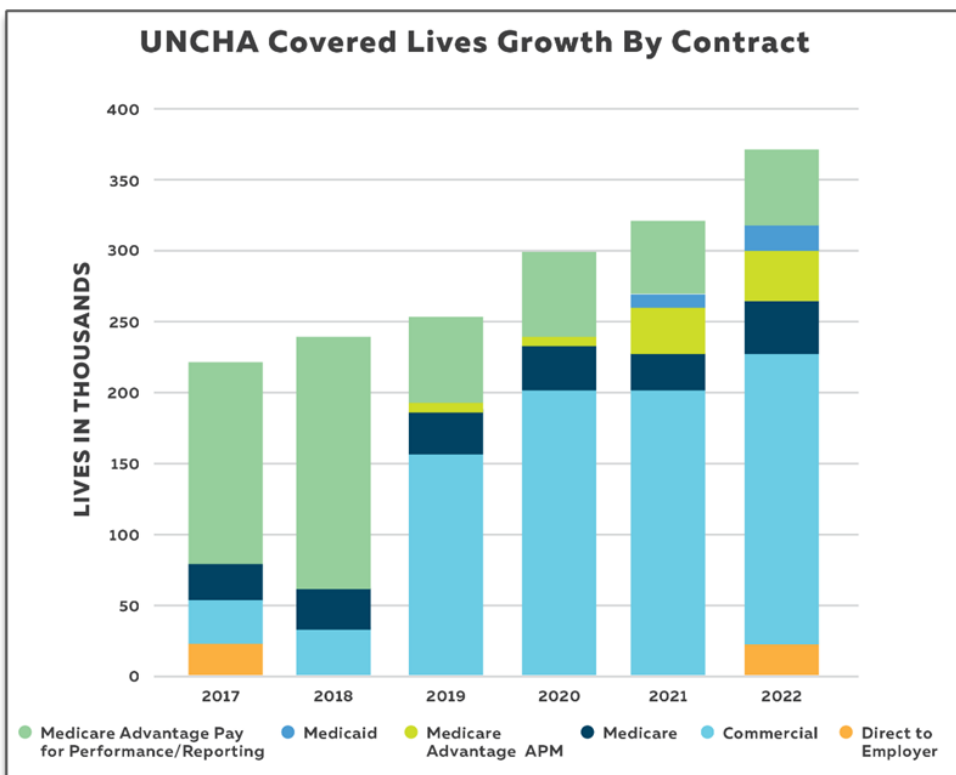

**How do you create a preferred  
post-acute network to improve LOS  
and reduce readmissions?**

# PAC Network: A Development Framework

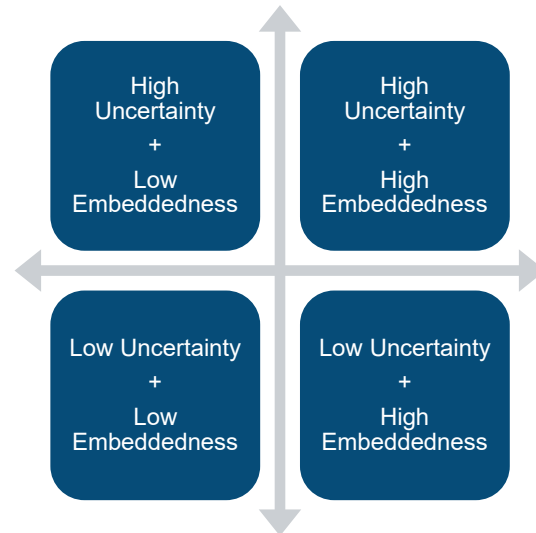

- Structural contingency theory – no one structure is ideal for every market
- Matrix as a guide for level of integration needed for success
- **Key output: vertical integration vs. virtual integration**

\*Adapted from McHugh et al., *Health Care Management Review*, 01 Jan 2020, 45(1):73-82

# PAC Network: A Development Framework

---



- Early internal stakeholder engagement is critical as you assess your baseline internal processes
- Identify internal strengths/weaknesses, define current workflows, root cause analysis
- **Key output: primary objectives, core internal metrics/KPIs**

# PAC Network: A Development Framework

---

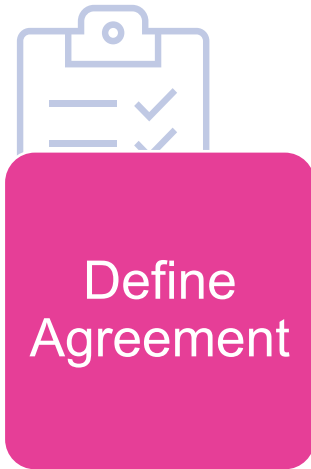

- Construct your affiliation agreement to support internal metrics/KPIs, but remember the value proposition for affiliates
- Outline terms of engagement in detail – standard report outs and cadence, metrics, citizenship requirements
- What are you offering in exchange for alignment? Do you have internal stakeholder engagement to execute?
- Is there a penalty for poor performance?
- **Key output: actionable affiliation agreement driving internal objectives, holding value for affiliates**

# PAC Network: A Development Framework

---



- Granular data + robust analytics are the fuels that will propel your QI engine and drive outcomes
- Lagging claims vs real-time clinical data
- Consider reporting requirements – scorecards, predictive analytics, data sharing with affiliates
- Your needs will likely evolve over time – keep this in mind when contracting
- **Key output: versatile granular data source and analytics platform**

**What are interventions to enhance utilization of the post-acute care network?**

# Utilization

## Effective Utilization Requires Collaboration

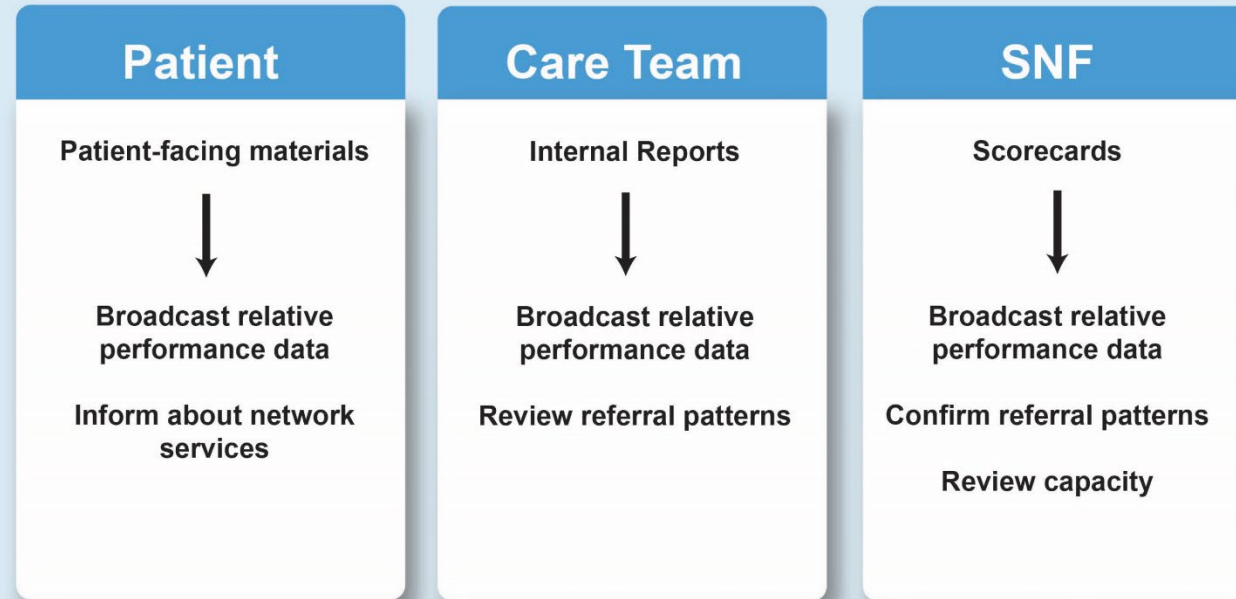

Use Data To Effect Change

**What are strategies to achieve targeted goals for LOS and readmissions?**

# Embedded Care Management

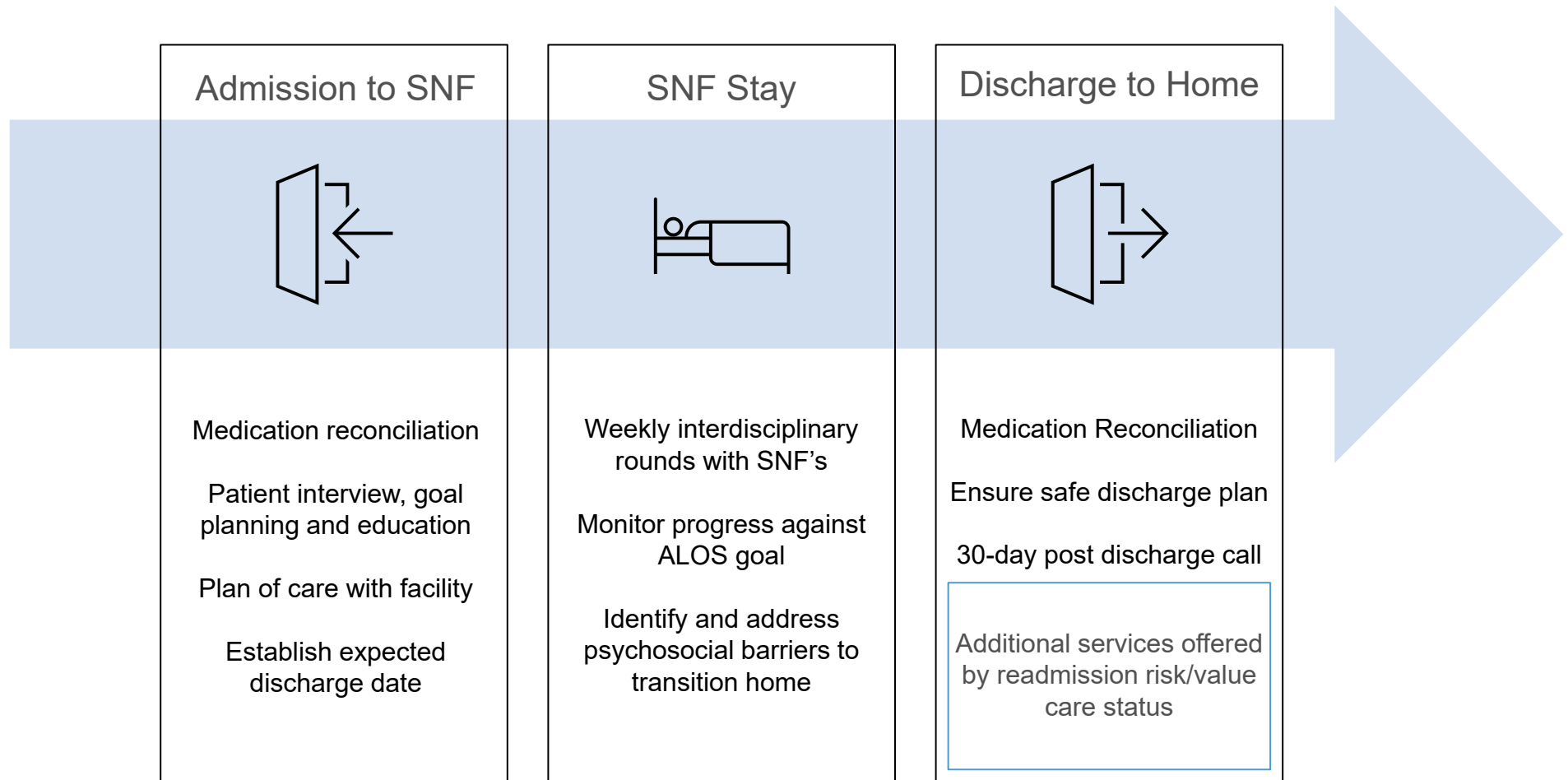

# A Focus on Home Health

---

## Telehealth and COVID-19 are Transforming Home Health

- 2.5% increase in inpatient disposition to home health from 2019 to 2020\*
- Staffing shortages are driving home health to technology solutions (RPM), enhancing comfort with telehealth adoption
- Increased reliance on home health during the pandemic has led to QI interest in the space
- Creative partnerships between PAC networks and home health, particularly telehealth-based, hold significant potential

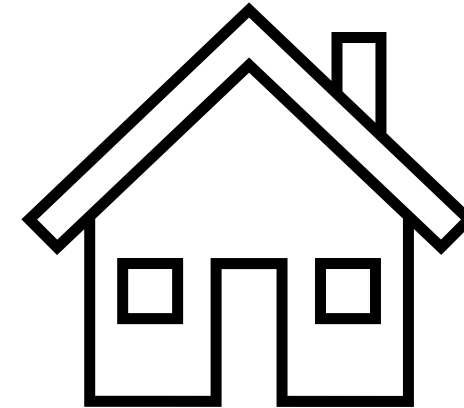

\* Post-Acute Care Industry Trend Report 2021, Trella Health

# A Focus on Home Health: Targeting Post-Discharge Readmissions

## Enhanced Home Health Reduces Readmissions

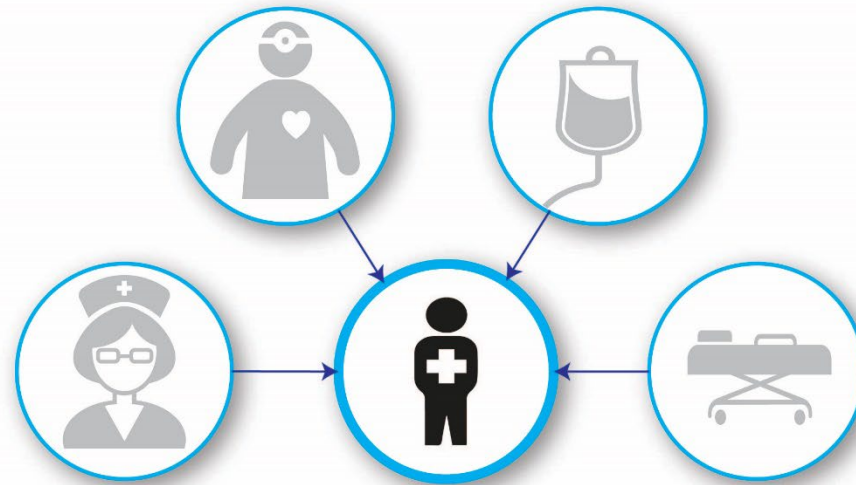

Intensive nursing and telehealth provider support + rapid deployment home infusion/DME after home discharge

Blends subacute and residential spaces

Nearly 50% reduction in readmissions over traditional home health over 12 months

Ongoing pilot of high-readmission-risk patients from SNF

# A Focus on Home Health: Targeting SNF Avoidance

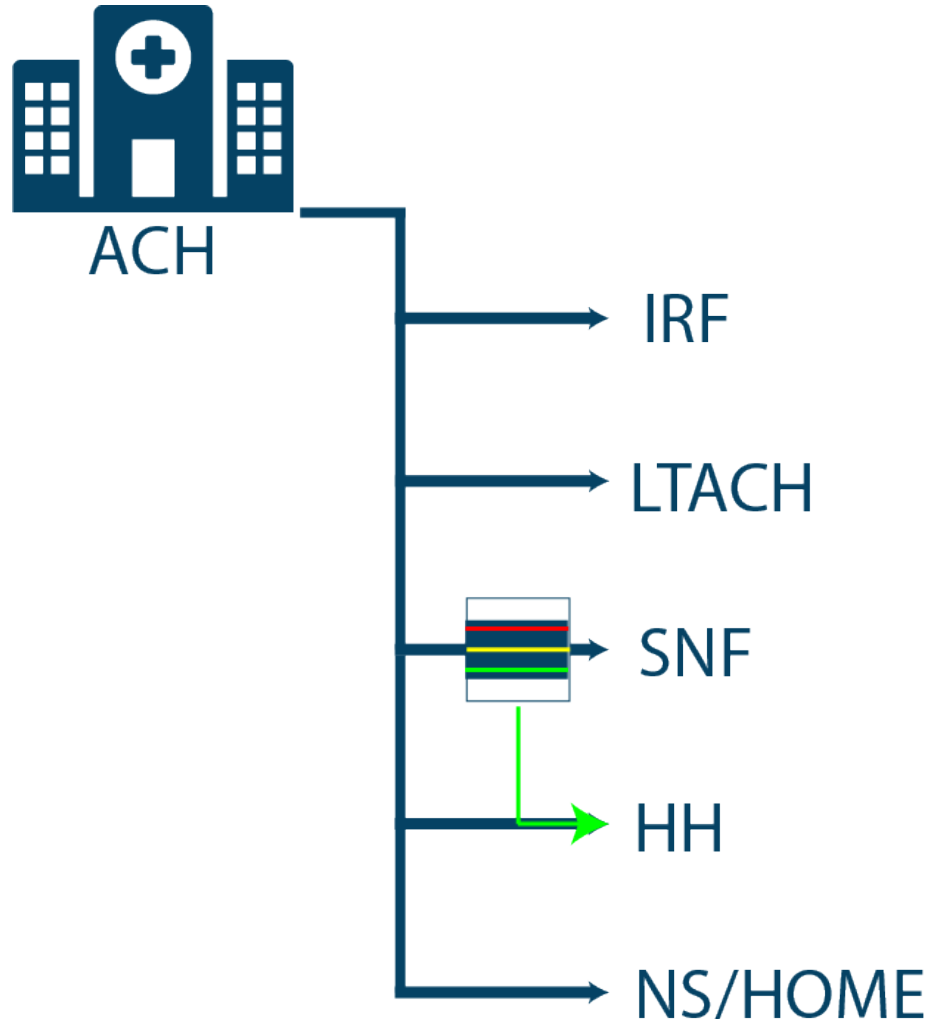

## Home Health May Offer Cost Savings Over SNFs For Marginal Patients

2019 cohort study Medicare data, 17 million hospitalizations, DRG stratified\*

- 60-day cost of care traditional home health vs SNF, -\$4500
- 5.6% relative increase in 30-day readmission rate for home health
- No significant difference in functional status and mortality rates at 60 days post-discharge

### Implications?

- A segment of low-risk/marginal patients may benefit from disposition to home health rather than SNF
- Enhancing supports in this population (increased provider-level care supervision, increased home PT frequency/intensity) may broaden the segment
- Not quite “SNF at home” but shares similarities

\*Werner et al, *JAMA Intern Med.* 2019;179(5):617-623. doi:10.1001/jamainternmed.2018.7998



**Thank you!**